

SPECIFICATION DRAWING

DAQU CONFIGURATION

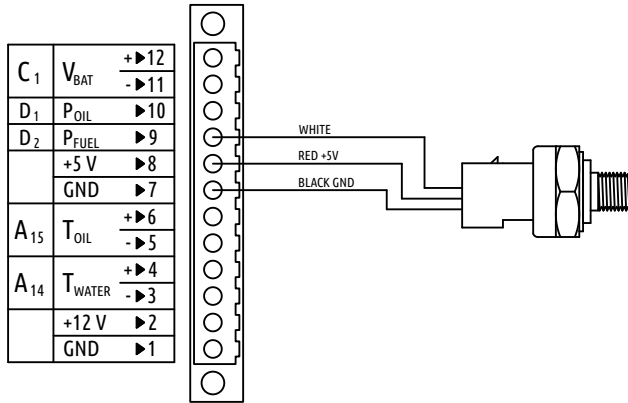

OPTION	SELECTION/SETTING
CHANNEL	Any B,D or E
FUNCTION	FUEL PRESSURE
SENSOR	Active 0.5-4.5V
REPORT TIME	0.5 – 1.0 s
FREQUENCY	1Hz - 2Hz
FILTER	2000ms or 2s
MAX VALUE*	1.034 BAR

*Always enter MAX VALUE in BAR.
Do not enter PSI value!

PART PHOTO/DRAWING

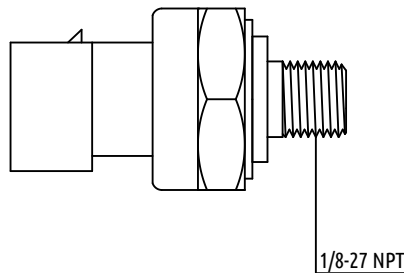

SPECIFICATION

WEIGHT	40g
OUTPUT	0.5-4.5V
RANGE	0-15PSI
MAX VALUE(at 4.5V)	15PSI or 1.034BAR
BURST PRESSURE	600PSI or 41BAR
PRINCIPLE	VENTED GAUGE

NOTES

- Typically used for fuel pressure on carburetor engines.
- NPT threads are NOT self-sealing! Thread sealant must be used!
- Do not overtight or housing may break!

PART NUMBER: S-PR-KAV-1B-NPT		You can also find this product under part numbers: KAVLICO P4055-5025-1		
FILE NAME: ~/Shared/Sensors/S-PR-KAV-1B-NPT.dxf				
TITLE: Pressure Sensor 15PSI/1BAR		KANARDIA d.o.o. Lopata 24a 3000 Celje Slovenia		
DATE: 10.3.2022	SCALE: N/A			SHEET: 1 of 1
REV: A	DRAW BY: ŽP			CHECK BY: GT

REV	DATE	DESCRIPTION	DR
A	10.3.2022	Initial release.	ŽP