

SPECIFICATION DRAWING

DAQ CONFIGURATION

OPTION	SELECTION/SETTING
CHANNEL	Any B,D or E
FUNCTION	OIL PRESSURE
SENSOR	Active 0.5-4.5V
REPORT TIME	0.5 - 1.0 s
FREQUENCY	1Hz - 2Hz
FILTER	2000ms/2s
MAX VALUE*	10.34 BAR

*Always enter MAX VALUE in BAR.
Do not enter PSI value!

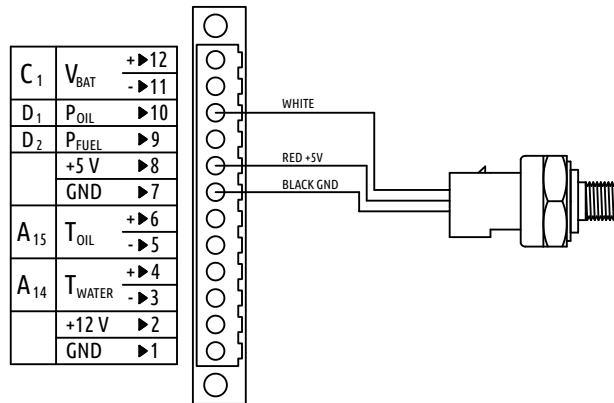

PART PHOTO/DRAWING

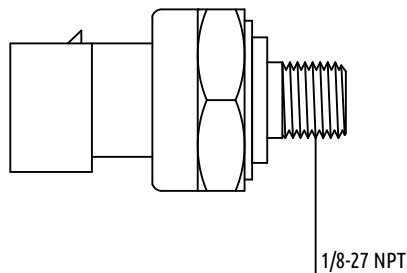

SPECIFICATION

WEIGHT	40g
OUTPUT	0.5-4.5V
RANGE	0-150PSI
MAX VALUE(at 4.5V)	150PSI or 10.34BAR
BURST PRESSURE	600PSI or 41BAR
PRINCIPLE	VENTED GAUGE

NOTES

- Typically used for oil pressure on Lycoming, Continental and older Rotax engines (check thread on your Rotax engine).
- It can also be used as fuel pressure on injection engines.
- NPT threads are NOT self-sealing! Thread sealant must be used!
- Do not overtight or housing may break!

PART NUMBER:

S-PR-KAV-10B-NPT

You can also find this product under part numbers:
KAVLICO P4055-5025-6

FILE NAME: ~/Shared/Sensors/S-PR-KAV-10B-NPT-B.dxf

TITLE: Pressure Sensor 150PSI/10BAR

KANARDIA d.o.o.
Lopata 24a
3000 Celje
Slovenia

REV	DATE	DESCRIPTION	DR
A	10.3.2022	Initial release.	ŽP

DATE:	10.3.2022	SCALE:	N/A	SHEET:	1 of 1
DRAW BY:	ŽP	CHECK BY:	GT	REV:	A