

INDU VARIOMETER

Manual

Kanardia d.o.o.

February 2020



© Kanardia d.o.o.

Revision 1.1

Contact Information

Publisher and producer:

Kanardia d.o.o.

Lopata 24a

SI-3000

Slovenia

Tel: +386 40 360 512

Email: info@kanardia.eu

A lot of useful and recent information can be also found on the Internet. See <http://www.kanardia.eu> for more details.

Copyright

This document is published under the *Creative Commons, Attribution-ShareAlike 3.0 Unported* licence. Full license is available on <http://creativecommons.org/licenses/by-sa/3.0/legalcode> web page and a bit more human readable summary is given on <http://creativecommons.org/licenses/by-sa/3.0/>. In short, the license gives you right to copy, reproduce and modify this document if:

- you cite Kanardia d.o.o. as the author of the original work,
- you distribute the resulting work only under the same or similar license to this one.

Credits

This document was written using TeTeX (L^AT_EX) based document creation system using Kile running on Linux operating system. Most

of the figures were drawn using Open Office Draw and Inkscape applications. Photos and scanned material was processed using Gimp. Sam2p was used to convert pictures into eps format. All document sources are freely available on request under the licence mentioned above and can be obtained by email. Please send requests to info@kanardia.eu.

Revision History

The following table shows the revision history of this document.

Rev.	Date	Description
1.0	Oct 2015	Initial release
1.1	Feb 2020	Revision

Contents

1	Introduction	4
1.1	General Description	4
1.2	Technical Specification	4
1.3	Options	5
1.3.1	Display	5
2	Installation	7
2.1	Mounting Dimensions	7
2.2	Connections	7
2.2.1	Static Pressure - Pst	7
2.2.2	CAN Bus - CAN	8
2.2.3	Illumination	9
2.2.4	Power - POWER	10
3	Maintenance & Repair	10
4	Sensor Calibration	11
4.1	Calibration Procedure	11
4.2	Pressure Altitude Calculation	11
4.3	Altitude Derivative	12
5	Limited Conditions	12
5.1	Warranty	13
5.2	TSO Information	15

1 Introduction

First of all, we would like to thank you for purchasing our device. Indu variometer is an electronic device, which mimics classical variometer construction and combines it with the state of the art electronics. This results in the best of both worlds; a perfect and intuitive analogue reading combined with high precision of modern electronics. This manual describes the technical description of the unit, installation and operation.

CAUTION: Indu Variometer is not TSO approved as a flight instrument.

1.1 General Description

The variometer is an electromechanical device. It consist of high precision electronic barometric sensor, which provides static pressure information in digital form. The electronics reads the pressure sensor and numerically calculates the altitude change. The result drives stepper motor turning a needle. The calculated rate of change is also shown on a colour LCD display. When connected to a CAN bus the variometer outputs the vertical speed information. Analog scale is divided lineary with a zero speed on the left side. An optional dim knob can be connected to the device and it is used to adjust the brightness of the screen.

1.2 Technical Specification

Table 1 shows some basic technical specification of Indu variometer.

Description	Value
Weight	57 mm: 150 g 80 mm: 200 g
Size (with connectors)	57 mm: 60 x 60 x 66 mm 80 mm: 82 x 82 x 66 mm
Panel hole (standard fit)	80 mm (3.15 inch) 57 mm (2.25 inch)
Altitude range	-500 to 15000 m, (-1500 to 45000 feet)
Operational voltage	8 to 32 V
Power consumption	1.2 W
Current	100 mA at 12 V, 50 mA at 24 V
Operating temperature	-30 °C to +85 °C
Humidity	30 % -90 %, non condensing
Barometric sensor	24 bit, 10-1200 hPa, 20 cm resolution
Communication	CAN bus, 29 bit header, 500 kbit, Kanardia protocol

Table 1: Basic technical specifications.

1.3 Options

The instrument is available in two different sizes, different scale units and different scale ranges. The scale units and range must be specified at the time of order.

The variometer is available in meters per second and feet per minute units. The standard range is ± 10 m/s or ± 2000 fpm.

Different units and range is also possible with additional charges.

1.3.1 Display

Standard LCD display layout displays two values: Vario on top of the screen and flight time on the bottom.

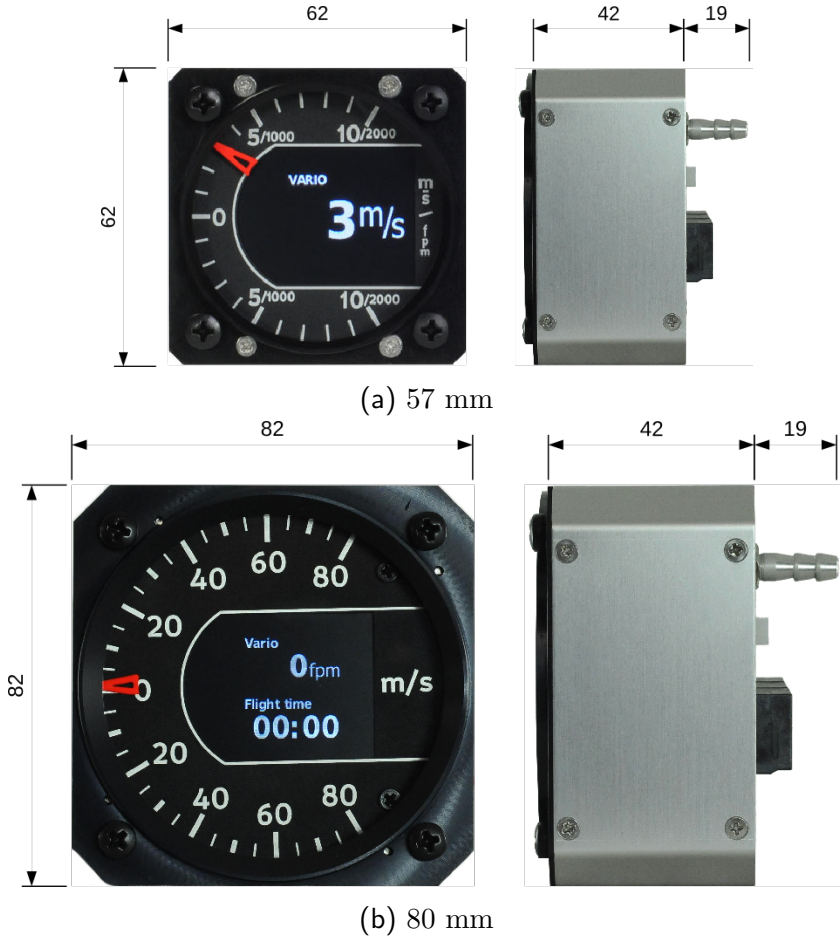

Figure 1: Front and side view of the variometer with its principal dimensions.

If you want a different LCD display layout, you can configure it yourself with our Customizer desktop application.¹ This option requires Kanardia's Blu device for transferring the configuration from your an-

¹ Available from April 2020

droid device to your Indu Variometer. Please read our Customizer Manual for more information.

2 Installation

The Indu variometer requires a standard size 80/57 mm hole in the instrument panel. The position of the hole must ensure visibility from the pilot's perspective.

2.1 Mounting Dimensions

The mounting screw holes are located on a circle of 89/65 mm diameter. The instrument is mounted using four screws type M4. To prevent internal stresses, please make sure that the instrument panel is flat. It is highly recommended that the instrument panel is mounted using rubber shocks, which reduce the vibrations. Figure 2 illustrates the panel cutout and mounting holes.

2.2 Connections

Figure 3 illustrates all connections at the back side of the instrument.

2.2.1 Static Pressure - Pst

Indu Variometer must be connected to the static pressure source. Static pressure source is usually obtained from pressure sources located on the fuselage side surfaces or from the static port on the pitot tube.

Locate the existing tube, cut it at an appropriate place and insert a T junction. Install a new tube from junction to the instrument.

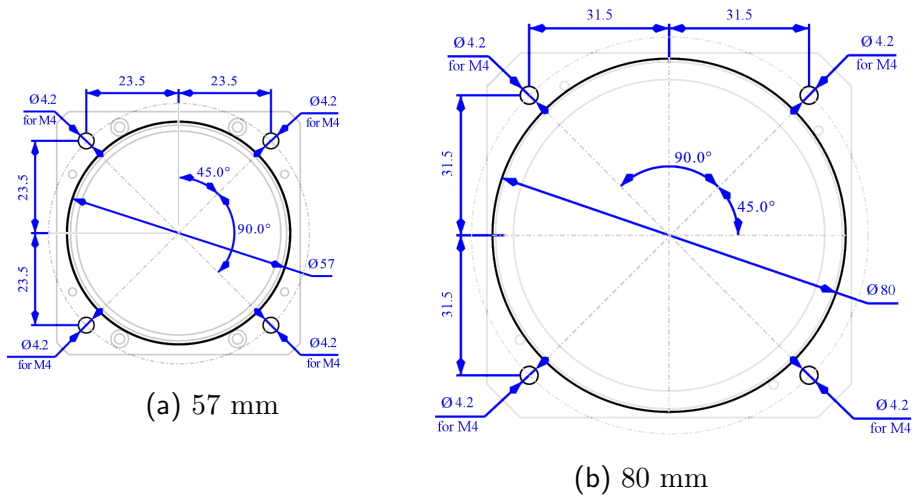

Figure 2: Instrument panel cutout and mounting hole. Note: Figures are not in scale.

It is highly recommended to keep the static tubing as short as possible. The tubing must avoid sharp bends and twists. The tubing must be airtight. Water must not be allowed to enter the tubing.

It is strongly recommended to label each tube before connecting to Indu Variometer. This will help a lot if you ever have to remove and re-install the instrument.

2.2.2 CAN Bus - CAN

Connection to the CAN bus is optional and is not required for the normal operation.

Use standard RJ45 ethernet cable to connect it with other Kanardia equipment.

When connected to the bus, variometer will transmit vertical speed to other units connected on the bus.



Figure 3: Back view of the 80 mm instrument with connections.

2.2.3 Illumination

LCD display brightness level can be adjusted. Here are two options: new instruments have a push-rotate knob, while older instruments have only rotating knob. When Indu Variometer is connected to the CAN bus, the knob adjusts brightness of all instruments connected to the bus.

On instruments with a push knob, simply push the knob, adjust the brightness and push the knob once more.

For instruments with only rotation knob, an optional external illumination knob can be connected to the back of the instrument. Illumination knob part number is I-ALT-ILLUM and it must be ordered separately. Please refer also to section ?? on page ?? for the activation procedure.

2.2.4 Power - POWER

Connect supplied connector at the back of Indu Variometer. The connector has a notch on one side, which protects from wrong orientation.

Connect blue lead to negative (ground) terminal and red lead to positive (+12-24 V) terminal.

The cable side of power connector consists of the following parts:

- plastic part with a hook ... Würth Elektronik, PN 649 002 113 322,
- two female crimp terminals ... Würth Elektronik, PN 649 006 137 22,
- 0.75 mm² (about AWG 18) red and blue leads.

The terminals have finite number of mating cycles. They belong to the 25 mating cycles quality class.

The power input shall be routed through a suitable circuit breaker.

3 Maintenance & Repair

No special maintenance is required. A static leak test should be performed annually and calibration check biannually. In the case of small deviation, use the procedure described in section ??.

The instrument has no serviceable parts inside. In the case of malfunction, it must be sent to factory for a repair.

4 Sensor Calibration & Altitude Calculation

4.1 Calibration Procedure

Each unit is factory calibrated against reference barometer at different pressure points. In standard calibration range we calibrate in following pressure sequence: 1100, 1000, 900, 800, 700, 600, 500, 400, 280, 550, 650, 750, 850, 950 and 1050 hPa. These measurements are then repeated at different temperatures ranging from -10 to 60 °C in 7 °C steps.

Please note that FAA Part 43, Appendix E does not require calibration/verification at different temperatures. But temperature calibration is essential for any electronic sensor.

This means that each instrument is calibrated against $13 \cdot 11 = 143$ different temperature - pressure pairs. The least squares method is then applied on this results in order to obtain corrections coefficients. A two dimensional, third degree polynomial is used for the correction model.

You can't change calibration parameters, but you can adjust the altitude. Please refer to the section ?? for more details.

4.2 Pressure Altitude Calculation

Pressure altitude is calculated according to the ISA 1976 model of atmosphere. First two atmosphere layers are used; throposphere and thropopause. The throposphere is modeled by equation (1) up to 11000 meters of geopotential altitude. The thropopause layer is modeled by equation (2) up to 20000 meters of geopotential altitude. As the pressure sensor is calibrated down to 100 hPa (about 16000 meters) altitudes above 16000 meters are not reliable.

$$p = p_0 \left[\frac{T_0 + T'_0 \cdot z}{T_0} \right]^{\frac{-g_0}{RT'_0}} \quad (1)$$

$$p = p_1 \exp \left[-\frac{g_0(z - z_1)}{RT_1} \right] \quad (2)$$

The equations convert geopotential altitude into pressure. Here z means geopotential altitude, $g_0 = 9.806645 \text{ m/s}^2$ is gravity constant, $R = 287.0528 \text{ N} \cdot \text{m/kg} \cdot \text{K}$ is gas constant for dry air, $p_0 = 1013.25 \text{ hPa}$ is standard pressure at sea level, $p_1 = 226.321 \text{ hPa}$ is standard pressure at troposphere/tropopause limit, $z_1 = 11000 \text{ m}$ is geopotential altitude of the limit, $T_0 = 288.15 \text{ K}$ is temperature at sea level, $T_1 = 216.65 \text{ K}$ is temperature at limit and $T'_0 = -0.0065 \text{ K/m}$ is temperature gradient in troposphere.

Besides the equations given below, their inverse and derivatives of inverse are also used.

4.3 Altitude Derivative

Altitude calculated from pressure is numerically derived to get rate of altitude change – vertical speed. The derivative is mathematically correct and as such does not introduce any error. We are using multiple point numerical derivation.

5 Limited Conditions

Although a great care was taken during the design, production, storage and handling, it may happen that the Product will be defective in some way. Please read the following sections about the warranty and the limited operation to get more information about the subject.

5.1 Warranty

Kanardia d.o.o. warrants the Product manufactured by it against defects in material and workmanship for a period of twenty-four (24) months from retail purchase.

Warranty Coverage

Kanardia's warranty obligations are limited to the terms set forth below:

Kanardia d.o.o. warrants the Kanardia-branded hardware product will conform to the published specification when under normal use for a period of twenty-four months (24) from the date of retail purchase by the original end-user purchaser ("Warranty Period"). If a hardware defect arises and a valid claim is received within the Warranty Period, at its option and as the sole and exclusive remedy available to Purchaser, Kanardia will either (1) repair the hardware defect at no charge, using new or refurbished replacement parts, or (2) exchange the product with a product that is new or which has been manufactured from new or serviceable used parts and is at least functionally equivalent to the original product, or, at its option, if (1) or (2) is not possible (as determined by Kanardia in its sole discretion), (3) refund the purchase price of the product. When a refund is given, the product for which the refund is provided must be returned to Kanardia and becomes Kanardia's property.

Exclusions and Limitations

This Limited Warranty applies only to hardware products manufactured by or for Kanardia that have the "Kanardia" trademark, trade name, or logo affixed to them at the time of manufacture by Kanardia. The Limited Warranty does not apply to any non-Kanardia

hardware products or any software, even if packaged or sold with Kanardia hardware. Manufacturers, suppliers, or publishers, other than Kanardia, may provide their own warranties to the Purchaser, but Kanardia and its distributors provide their products *AS IS*, without warranty of any kind.

Software distributed by Kanardia (with or without the Kanardia's brand name including, but not limited to system software) is not covered under this Limited Warranty. Refer to the licensing agreement accompanying such software for details of your rights with respect to its use.

This warranty does not apply: (a) to damage caused by use with non-Kanardia products; (b) to damage caused by accident, abuse, misuse, flood, fire, earthquake or other external causes; (c) to damage caused by operating the product outside the permitted or intended uses described by Kanardia; (d) to damage caused by service (including upgrades and expansions) performed by anyone who is not a representative of Kanardia or an Kanarida Authorized Reseller; (e) to a product or part that has been modified to significantly alter functionality or capability without the written permission of Kanardia; (f) to consumable parts, such as batteries, unless damage has occurred due to a defect in materials or workmanship; or (g) if any Kanardia serial number has been removed, altered or defaced.

To the extent permitted by applicable law, this warranty and remedies set forth above are exclusive and in lieu of all other warranties, remedies and conditions, whether oral or written, statutory, express or implied, including, without limitation, warranties of merchantability, fitness for a particular purpose, non-infringement, and any warranties against hidden or latent defects. If Kanardia cannot lawfully disclaim statutory or implied warranties then to the extent permitted by law, all such warranties shall be limited in duration to the duration of this express warranty and to repair or replacement service as determined by Kanardia in its sole discretion. Kanardia does not

warrant that the operation of the product will be uninterrupted or error-free. Kanardia is not responsible for damage arising from failure to follow instructions relating to the product's use. No Kanardia reseller, agent, or employee is authorized to make any modification, extension, or addition to this warranty, and if any of the foregoing are made, they are void with respect to Kanardia.

Limitation of Liability

To the extent permitted by applicable law, Kanardia is not responsible for indirect, special, incidental or consequential damages resulting from any breach of warranty or condition, or under any other legal theory, including but not limited to loss of use; loss of revenue; loss of actual or anticipated profits (including loss of profits on contracts); loss of the use of money; loss of anticipated savings; loss of business; loss of opportunity; loss of goodwill; loss of reputation; loss of, damage to or corruption of data; or any other loss or damage howsoever caused including the replacement of equipment and property, any costs of recovering, programming, or reproducing any program or data stored or used with Kanardia products and any failure to maintain the confidentiality of data stored on the product. Under no circumstances will Kanardia be liable for the provision of substitute goods or services. Kanardia disclaims any representation that it will be able to repair any product under this warranty or make a product exchange without risk to or loss of the programs or data. Some jurisdictions do not allow for the limitation of liability for personal injury, or of incidental or consequential damages, so this limitation may not apply to you.

5.2 TSO Information — Limited Operation

This product is not TSO approved as a flight instrument. Therefore, the manufacturer will not be held responsible for any damage caused

by its use. The Kanardia is not responsible for any possible damage or destruction of any part on the airplane caused by default operation of instrument.